

RC2207

Voltage Controlled Oscillator

Features

- Excellent temperature stability — 20 ppm/°C
- Linear frequency sweep
- Adjustable duty cycle — 0.1% to 99.9%
- Two or four level FSK capability
- Wide sweep range — 1000:1 min.
- Logic compatible input and output levels
- Wide supply voltage range — ±4V to ±13V
- Low supply sensitivity ±0.15%/V
- Wide frequency range — 0.01 Hz to 1 MHz
- Simultaneous triangle and squarewave outputs

Applications

- FSK generation
- Voltage and current-to-frequency conversion
- Stable phase-locked loop
- Waveform generation triangle, sawtooth, pulse, squarewave
- FM and sweep generation

Description

The RC2207 is a monolithic voltage-controlled oscillator (VCO) integrated circuit featuring excellent frequency stability and a wide tuning range. The circuit provides simultaneous triangle and squarewave outputs over a frequency range of 0.01 Hz to 1 MHz. It is ideally suited for FM, FSK and sweep or tone generation as well as for phase-locked loop applications.

As shown in the Block Diagram, the circuit is comprised of four functional blocks: a variable-frequency oscillator which generates the basic periodic waveforms; four current switches actuated by binary keying inputs; and buffer amplifiers for both the triangle and squarewave outputs. The internal switches transfer the oscillator current to any of four external timing resistors to produce four discrete frequencies which are selected according to the binary logic levels at the keying terminals (pins 8 and 9).

The RC2207 has a typical drift specification of 20 ppm/°C. The oscillator frequency can be linearly swept over a 1000:1 range with an external control voltage; and the duty cycle of both the triangle and the squarewave outputs can be varied from 0.1% to 99.9% to generate stable pulse and sawtooth waveforms.

Block Diagram

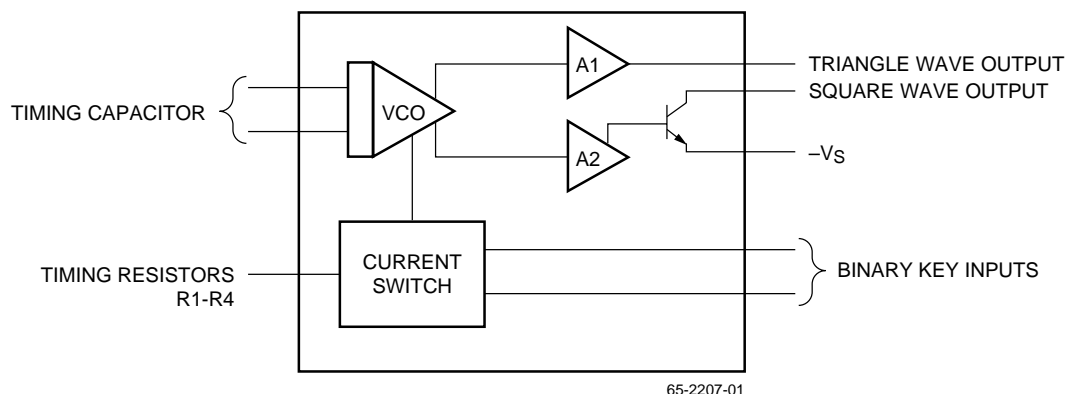

Pin Assignments

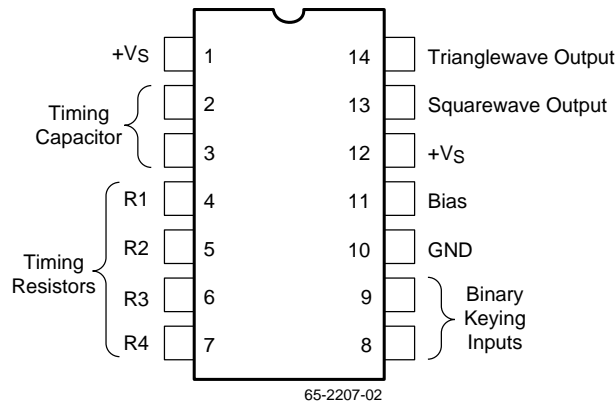

Pin Descriptions

Pin Name	Pin Number	Pin Function Description
Bias for Single Supply	11	For single supply operations, pin 11 should be externally biased to a potential between $+V_S/3$ and $+V_S/2$ (see Figure 8). The bias current at pin 11 is nominally 5% of the total oscillation timing current I_T .
Binary Keying Inputs	8, 9	The internal impedance at these pins is approximately $5\text{ k}\Omega$. Keying levels are $<1.4\text{V}$ for zero and $>3\text{V}$ for one logic levels referenced to the DC voltage at pin 10.
Ground	10	For split supply operation, this pin serves as circuit ground. For single supply operation, pin 10 should be AC grounded through a $1\text{ }\mu\text{F}$ bypass capacitor. During split supply operation, a ground current of $2 I_T$ flows out of this terminal, where I_T is the total timing current.
Squarewave Output	13	The squarewave output at pin 13 is an open-collector stage capable of sinking up to 20 mA of load current. R_L serves as a pull-up load resistor for this output. Recommended values for R_L range from $1\text{ k}\Omega$ to $10\text{ k}\Omega$.
Supply Voltage (+Vs, -Vs)	1, 12	The RC2207 is designed to operate over a power supply range of $+4\text{V}$ to $\pm 13\text{V}$ for split supplies, or 8V to 26V for single supplies. At high supply voltages, the frequency sweep range is reduced. Performance is optimum for $\pm 6\text{V}$, or 12V single supply operation.
Timing Capacitor	2, 3	The oscillator frequency is inversely proportional to the timing capacitor, C . The minimum capacitance value is limited by stray capacitances and the maximum value by physical size and leakage current considerations. Recommended values range from 100 pF to $100\text{ }\mu\text{F}$. The capacitor should be non-polarized.
Timing Resistors (R1–R4)	4–7	The timing resistors determine the total timing current, I_T , available to charge the timing capacitor. Values for timing resistors can range from $1.5\text{ k}\Omega$ to $2\text{ M}\Omega$; however, for optimum temperature and power supply stability, recommended values are $4\text{ k}\Omega$ to $200\text{ k}\Omega$. To avoid parasitic pick up, timing resistor leads should be kept as short as possible. For noise environments, unused or deactivated timing terminals should be bypassed to ground through $0.1\text{ }\mu\text{F}$ capacitors. Otherwise, they may be left open.
Trianglewave Output	14	The output at pin 14 is a trianglewave with a peak swing of approximately one-half of the total supply voltage. Pin 14 has a very low output impedance of 10Ω and is internally protected against short circuits. Notice that the triangle waveform linearity is sensitive to parasite coupling between the square and the trianglewave outputs (pins 13 and 14). In board layout or circuit wiring, care should be taken to minimize stray wiring capacitance between those pins.

Absolute Maximum Ratings

Parameter	Min.	Max.	Units
Supply Voltage		+26	V
Storage Temperature Range	-65	+150	V
Operating Temperature Range	-55	+125	°C
Lead Soldering Temperature (60 seconds)		+300	°C

Thermal Characteristics

	Ceramic DIP	SOIC	Plastic DIP
Maximum Junction Temperature	+175°C	+125°C	+125°C
Maximum P _D T _A < 50°C	1042 mW	300 mW	468 mW
Thermal Resistance, θ_{JC}	60°C/W	60°C/W	60°C/W
Thermal Resistance, θ_{JA}	120°C/W	200°C/W	160°C/W
For T _A > 50°C Derate at	8.33 mW/°C	5.0 mW/°C	6.25 mW/°C

Electrical Characteristics

(Test Circuit of Figure 1, $V_S = \pm 6V$, $T_A = +25^\circ C$, $C = 5000 \text{ pF}$, $R_1 = R_2 = R_3 = R_4 = 20 \text{ k}\Omega$, $R_L = 4.7\Omega$ binary inputs grounded, S1 and S2 closed unless otherwise specified)

Parameters		Test Conditions		Min.	Typ.	Max.	Units
General Characteristics							
Supply Voltage	Single Supply		See Typical Performance Characteristics	+8.0	+12	+26	V
	Split Supplies			± 4	± 6	± 13	V
Supply Current	Single Supply		Measured at pin 1, S1 open (See Fig. 8)		5.0	7.0	mA
	Split Supplies	Positive	Measured at pin 1, S1 open (See Fig. 7)	RC2207	5.0	7.0	mA
				RM2207		8.0	
	Split Supplies	Negative	Measured at pin 12, S1, S2 open	RC2207		7.0	mA
RM2207				4.0	6.0		
Binary Keying Inputs							
Switching Threshold			Measured at pins 8 and 9. Refer to pin 10.	1.4	2.2	2.8	V
Input Resistance					5.0		k Ω
Oscillator Section—Frequency Characteristics							
Upper Frequency Limit			$C = 500 \text{ pF}$, $R_3 = 2 \text{ k}\Omega$	0.5	1.0		MHz
Lower Practical Frequency			$C = 50 \text{ }\mu\text{F}$, $R_3 = 2 \text{ k}\Omega$		0.01		Hz
Frequency Accuracy					± 1.0	± 3.0	% of f_0
Frequency Matching					0.5		% of f_0
Frequency Stability	vs. Temperature (Note 1)		$0^\circ C < T_A < +70^\circ C$		20	50	ppm/ $^\circ C$
	vs. Supply Voltage				0.15		%/V
Sweep Range			$R_3 = 1.5 \text{ k}\Omega$ for f_H $R_3 = 2 \text{ M}\Omega$ for f_L	1000:1	3000:1		f $_H$ /f $_L$
Sweep Linearity			$C = 5000 \text{ pF}$				
	10:1 Sweep ¹		$f_H = 10 \text{ kHz}$, $f_L = 1 \text{ kHz}$		1.0	2.0	%
	1000:1 Sweep		$f_H = 100 \text{ kHz}$, $f_L = 100 \text{ Hz}$		5.0		%
FM Distortion			$\pm 10\%$ FM Deviation		0.1		%
Recommended Range of Timing Resistors			See Characteristic Curves	1.5		2000	k Ω
Impedance at Timing Pins			Measured at pins 4, 5, 6, or 7		75		Ω
DC Level at Timing Terminals					10		mV
Output Characteristics							
Triangle output	Amplitude		Measured at pin 14	4	6		V $_P$ -P
	Impedance				10		Ω
	DC Level		Referenced to pin 10		+100		mV
	Linearity		from 10% to 90% of swing		0.1		%
Squarewave Output	Amplitude		Measured at pin 13, S2 Closed	11	12		V $_P$ -P
	Saturation Voltage		Referenced to pin 12		0.2	0.4	V
	Rise Time		$C_L \leq 10 \text{ pF}$		200		ns
	Fall Time		$C_L \leq 10 \text{ pF}$		20		ns

Note:

1. Guaranteed by design.

Typical Performance Characteristics

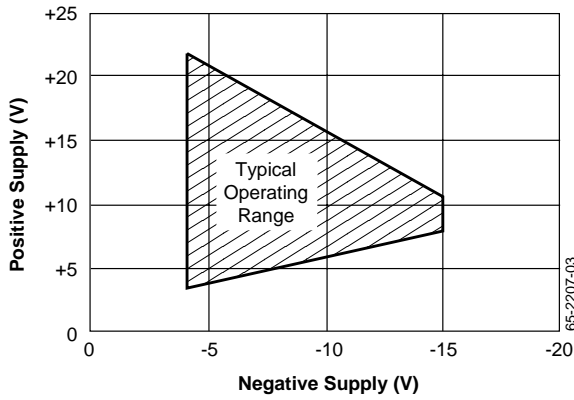

Figure 1. Typical Operating Range for Split Supply Voltage

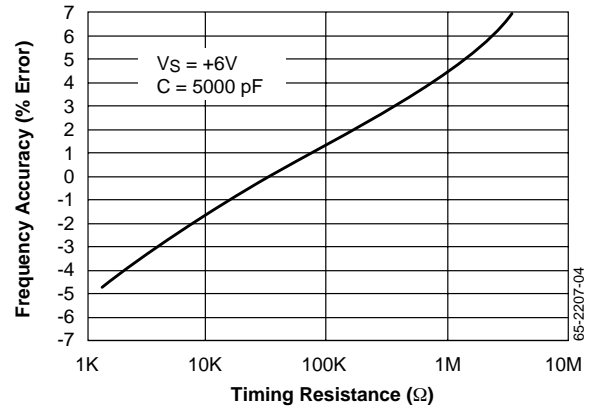
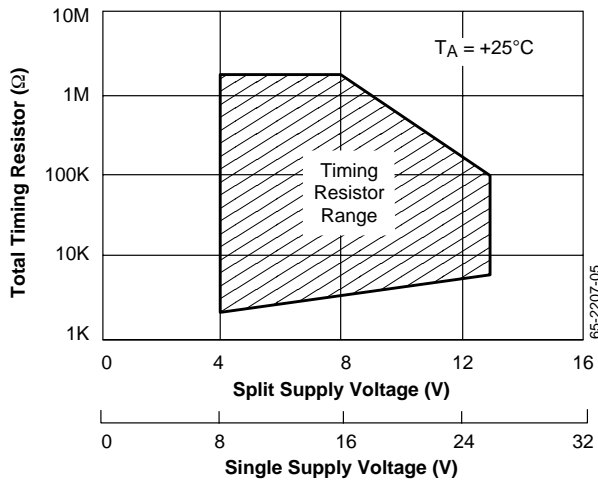

Figure 2. Frequency Accuracy vs. Timing Resistance



¹R_T = Parallel Combination of Activated Timing Resistors

Figure 3. Recommended Timing Resistor Value vs. Power Supply Voltage

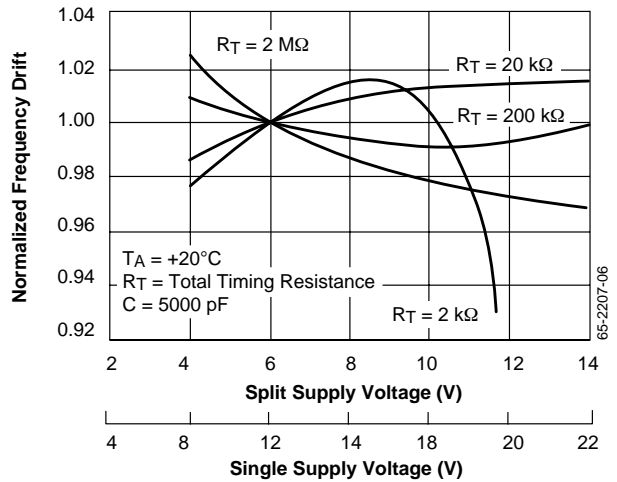

Figure 4. Normalized Frequency Drift vs. Supply Voltage

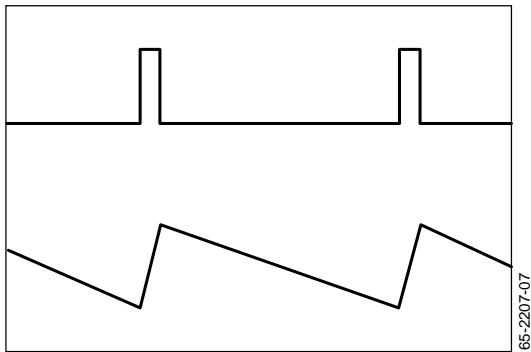

Figure 5. Pulse and Sawtooth Outputs

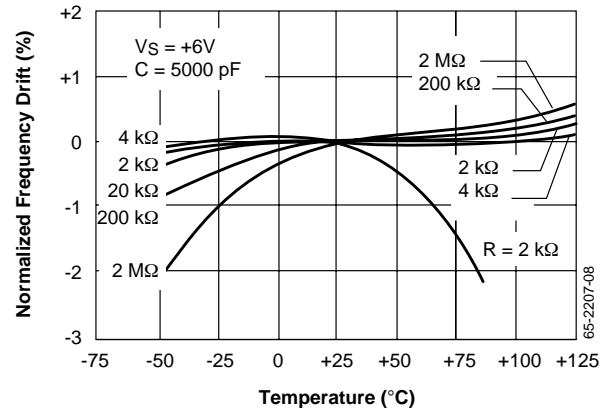

Figure 6. Normalized Frequency Drift vs. Temperature

Applications Information

Precautions

The following precautions should be observed when operating the RC2207 family of integrated circuits:

- Pulling excessive current from the timing terminals will adversely affect the temperature stability of the circuit. To minimize this disturbance, it is recommended that the total current drawn from pins 4, 5, 6 and 7 be limited to <6 mA. In addition, permanent damage to the device may occur if the total timing current exceeds 10 mA.
- Terminals 2, 3, 4, 5, 6 and 7 have very low internal impedance and should, therefore, be protected from accidental shorting to ground or the supply voltages.
- The keying logic pulse amplitude should not exceed the supply voltage.

Split Supply Operation

Figure 7 is the recommended circuit connection for split supply operation. The frequency of operation is determined by the timing capacitor (C) and the activated timing resistors (R1 through R4). The timing resistors are activated by the logic signals at the binary keying inputs (pins 8 and 9), as shown in Table 1. If a single timing resistor activated, the frequency is $1/RC$.

Otherwise, the frequency is either $1/(R1 \parallel R2)C$ or $1/(R1 \parallel R4)C$.

Table 1. Logic Table for Binary Keying Controls

Logic Level	Selected Timing Pins		Frequency	Definitions
	8	9		
0	6	f1	$f_1 = 1/R3C$	$\Delta f_1 = 1/R4C$
0	1	6 & 7	$f_1 + \Delta f_1$	$f_2 = 1/R2C$, $\Delta f_2 = 1/R1C$
1	0	5	f2	Logic levels: 0 = Ground
14	&5	$f_2 + f\Delta_2$	Logic levels:	1 = $\geq 3V$

Note:

1. For single supply operation, logic levels are referenced to voltage at pin 10.

The squarewave output is obtained at pin 13 and has a peak-to-peak voltage swing equal to the supply voltages. This output is an open-collector type and requires an external pull-up load resistor (nominally 5 k Ω) to the positive supply. The triangle waveform obtained at pin 14 is centered about ground and has a peak amplitude of $+V_S/2$.

The circuit operates with supply voltages ranging from $\pm 4V$ to it $\pm 13V$. Minimum drift occurs with $\pm 6V$ supplies.

Single Supply Operation

The circuit should be interconnected as shown in Figure 8 for single supply operation. Pin 12 should be grounded, and pin 11 biased from $+V_S$ through a resistive divider to a value of bias voltage between $+V_S/3$ and $+V_S/2$. Pin 10 is bypassed to ground through a 0.1 μF capacitor.

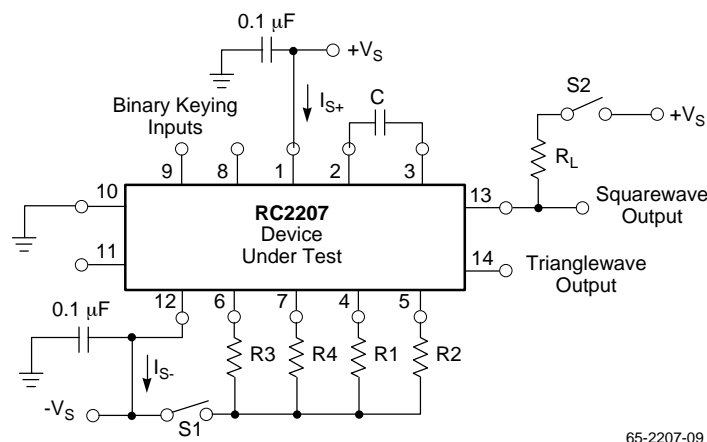

65-2207-09

Note: This circuit is for Bench Tests only. DC testing is normally performed with automated test equipment using an equivalent circuit.

Figure 7. Test Circuit for Split Supply Operation

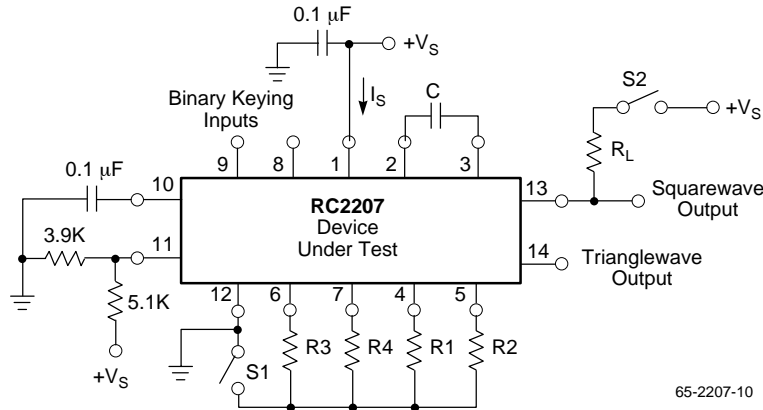

Figure 8. Test Circuit for Single Supply Operation

For single supply operation, the DC voltage at pin 10 and the timing terminals (pins 4 through 7) are equal and approximately 0.6V above V_B , the bias voltage at pin 11. The logic levels at the binary keying terminals are referenced to the voltage at pin 10.

On-Off Keying

The RC2207 can be keyed on and off by simply activating an open circuited timing pin. Under certain conditions, the circuit may exhibit very low frequency (<1 Hz) residual oscillation in the off state due to internal bias current. If this effect is undesirable, it can be eliminated by connecting a 10 MΩ resistor from pin 3 to +Vs.

Frequency Control (Sweep and FM)

The frequency of operation is controlled by varying the total timing current, I_T , drawn from the activated timing pin 4, 5, 6 or 7. The timing current can be modulated by applying a control voltage, V_C , to the activated timing pin through a series resistor R_C as shown in Figure 9.

For split supply operation, a negative control voltage, V_C , applied to the circuit of Figure 9 causes the total timing current, I_T , and the frequency, to increase.

As an example, in the circuit of Figure 9, the binary keying inputs are grounded. Therefore, only timing pin 6 is activated.

The frequency of operation determined by:

$$f = \frac{1}{R_3 C_B} \left[1 - \frac{V_C R_3}{(R_C)(-V_C)} \right] \text{Hz}$$

Pulse and Sawtooth Operation

The duty cycle of the output waveforms can be controlled by frequency shift keying at the end of every half cycle of oscillator output. This is accomplished by connecting one or both of the binary keying inputs (pin 8 or 9) to the square-wave output at pin 13. The output waveforms can then be converted to positive or negative pulses and sawtooth waveform.

Figure 10 is the recommended circuit connection for duty cycle control. Pin 8 is shorted to pin 13 so that the circuit switches between the 0 0 and the 1 0 logic states given in Table 1. Timing pin 5 is activated when the output is high, and pin 6 is activated when the squarewave output goes to a low state.

The duty cycle of the output waveforms given as:

$$\text{Duty Cycle} = \frac{R_2}{R_2 + R_3}$$

and can be varied from 0.1% to 99.9% by proper choice of timing resistors. The frequency of oscillation, f , is given as:

$$f = \frac{2}{C} \left[\frac{1}{R_2 + R_3} \right]$$

The frequency can be modulated or swept without changing the duty cycle by connecting R_2 and R_3 to a common control voltage V_C instead of to $-V_S$. The sawtooth and the pulse output waveforms are shown in the Typical Performance Characteristics Graphs.

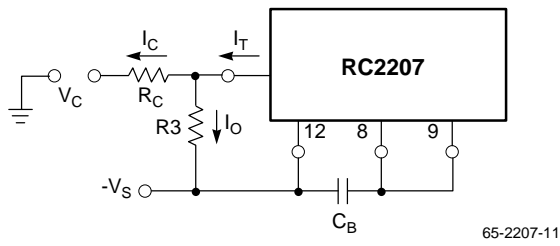

Figure 9. Frequency Sweep Operation

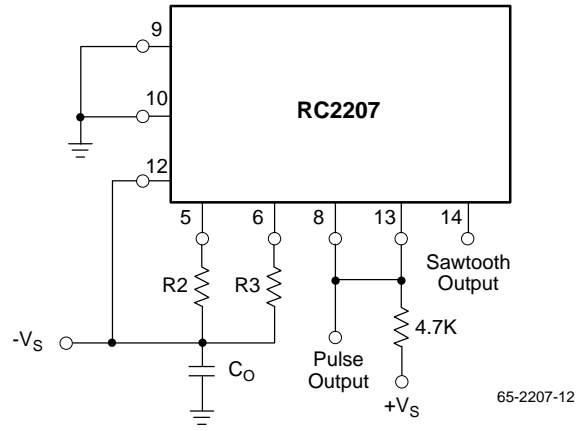

Figure 10. Pulse and Sawtooth Generation

Mechanical Dimensions

14-Lead SOIC

Symbol	Inches		Millimeters		Notes
	Min.	Max.	Min.	Max.	
A	.053	.069	1.35	1.75	
A1	.004	.010	0.10	0.25	
B	.013	.020	0.33	0.51	
C	.008	.010	0.19	0.25	5
D	.336	.345	8.54	8.76	2
E	.150	.158	3.81	4.01	2
e	.050 BSC		1.27 BSC		
H	.228	.244	5.79	6.20	
h	.010	.020	0.25	0.50	
L	.016	.050	0.40	1.27	3
N	14		14		6
α	0°	8°	0°	8°	
ccc	—	.004	—	0.10	

Notes:

1. Dimensioning and tolerancing per ANSI Y14.5M-1982.
2. "D" and "E" do not include mold flash. Mold flash or protrusions shall not exceed .010 inch (0.25mm).
3. "L" is the length of terminal for soldering to a substrate.
4. Terminal numbers are shown for reference only.
5. "C" dimension does not include solder finish thickness.
6. Symbol "N" is the maximum number of terminals.

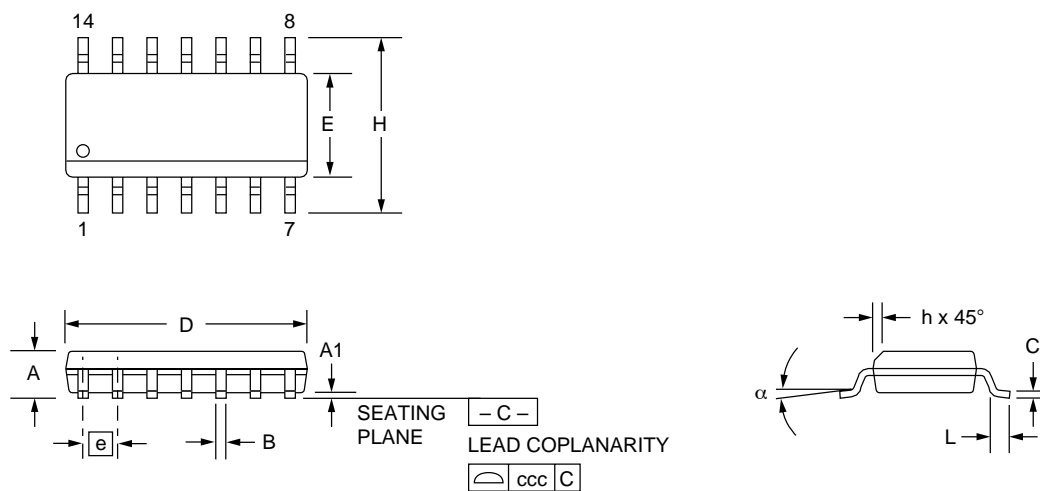

Mechanical Dimensions (continued)

14-Lead Plastic DIP

Symbol	Inches		Millimeters		Notes
	Min.	Max.	Min.	Max.	
A	—	.210	—	5.33	
A1	.015	—	.38	—	
A2	.115	.195	2.93	4.95	
B	.014	.022	.36	.56	
B1	.045	.070	1.14	1.78	
C	.008	.015	.20	.38	4
D	.725	.795	18.42	20.19	2
D1	.005	—	.13	—	
E	.300	.325	7.62	8.26	
E1	.240	.280	6.10	7.11	2
e	.100 BSC		2.54 BSC		
eB	—	.430	—	10.92	
L	.115	.200	2.92	5.08	
N	14		14		5

Notes:

1. Dimensioning and tolerancing per ANSI Y14.5M-1982.
2. "D" and "E1" do not include mold flashing. Mold flash or protrusions shall not exceed .010 inch (0.25mm).
3. Terminal numbers are shown for reference only.
4. "C" dimension does not include solder finish thickness.
5. Symbol "N" is the maximum number of terminals.

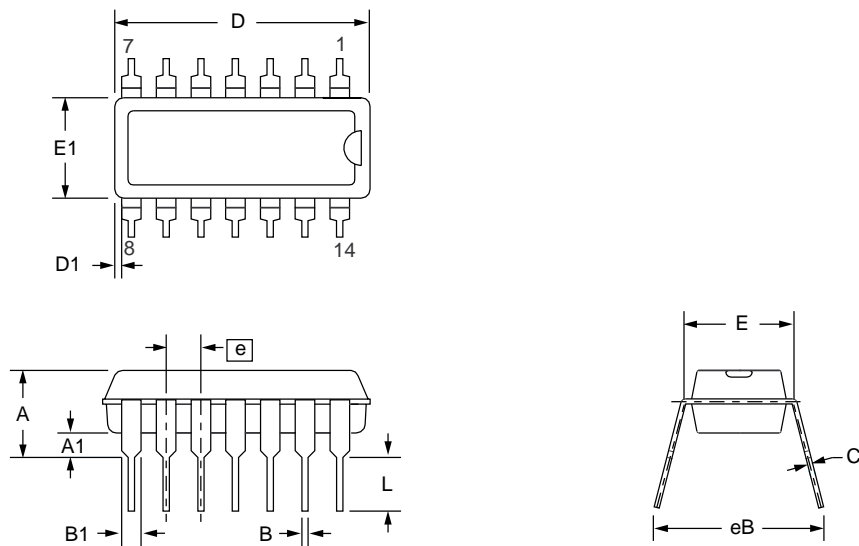

Mechanical Dimensions (continued)

14-Lead Ceramic DIP

Symbol	Inches		Millimeters		Notes
	Min.	Max.	Min.	Max.	
A	—	.200	—	5.08	
b1	.014	.023	.36	.58	8
b2	.045	.065	1.14	1.65	2
c1	.008	.015	.20	.38	8
D	—	.785	—	19.94	4
E	.220	.310	5.59	7.87	4
e	.100 BSC		2.54 BSC		5, 9
eA	.300 BSC		7.62 BSC		7
L	.125	.200	3.18	5.08	
Q	.015	.060	.38	1.52	3
s1	.005	—	.13	—	6
α	90°	105°	90°	105°	

Notes:

1. Index area: a notch or a pin one identification mark shall be located adjacent to pin one. The manufacturer's identification shall not be used as pin one identification mark.
2. The minimum limit for dimension "b2" may be .023 (.58mm) for leads number 1, 7, 8 and 14 only.
3. Dimension "Q" shall be measured from the seating plane to the base plane.
4. This dimension allows for off-center lid, meniscus and glass overrun.
5. The basic pin spacing is .100 (2.54mm) between centerlines. Each pin centerline shall be located within $\pm .010$ (.25mm) of its exact longitudinal position relative to pins 1 and 14.
6. Applies to all four corners (leads number 1, 7, 8, and 14).
7. "eA" shall be measured at the center of the lead bends or at the centerline of the leads when " α " is 90°.
8. All leads – Increase maximum limit by .003 (.08mm) measured at the center of the flat, when lead finish applied.
9. Twelve spaces.

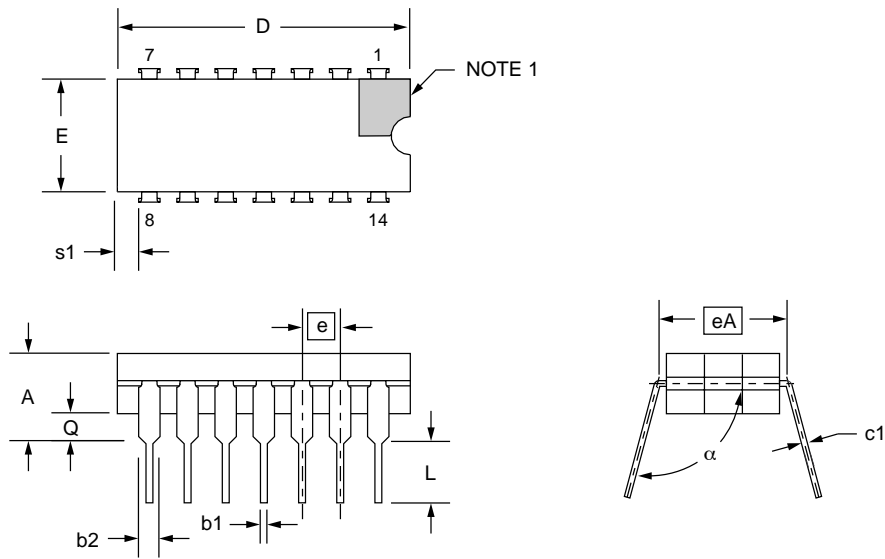

Ordering Information

Part Number	Package	Operating Temperature Range
RC2207M	14 Lead SOIC	0°C to +70°C
RC2207N	14 Lead Plastic DIP	0°C to +70°C
RV2207M	14 Lead SOIC	-25°C to +85°C
RV2207N	14 Lead Plastic DIP	-25°C to +85°C
RM2207D	14 Lead Ceramic DIP	-55°C to +125°C
RM2207D/883B	14 Lead Ceramic DIP	-55°C to +125°C

Note:

1. /883B suffix denotes MIL-STD-883, Level B processing

LIFE SUPPORT POLICY

FAIRCHILD'S PRODUCTS ARE NOT AUTHORIZED FOR USE AS CRITICAL COMPONENTS IN LIFE SUPPORT DEVICES OR SYSTEMS WITHOUT THE EXPRESS WRITTEN APPROVAL OF THE PRESIDENT OF FAIRCHILD SEMICONDUCTOR CORPORATION. As used herein:

1. Life support devices or systems are devices or systems which, (a) are intended for surgical implant into the body, or (b) support or sustain life, and (c) whose failure to perform when properly used in accordance with instructions for use provided in the labeling, can be reasonably expected to result in a significant injury of the user.
2. A critical component in any component of a life support device or system whose failure to perform can be reasonably expected to cause the failure of the life support device or system, or to affect its safety or effectiveness.